

# OXYGEN ABSORBER



## Product Description

Stream Peak's Oxygen Absorber, O Sorb, is made from safe, non-toxic material. The Oxygen Absorber can be used to prolong the shelf life of food produce.

O Sorb is also known as oxygen scavengers or oxygen absorbent.

Commonly used in food packaging such as pastries and snacks, oxygen absorbers are capable of reducing the aerobic environment to 0% oxygen. It prevents changes in the colour of food, stop oils in food from becoming rancid, and retards the growth of oxygen-using aerobic microorganisms such as fungi.

Without any aerobic bacteria and fungi growth, the shelf life of a food product will extend from 1 week to several months.

## Industries Served

- Food And Beverage



**STREAM PEAK INTERNATIONAL PTE LTD**  
Tel: +65 6610 7921 | Fax: +65 6862 2520  
Email: [enquiry@streampeak.com.sg](mailto:enquiry@streampeak.com.sg)

*Valuing Relationships, Protecting Goods*  
Address: 26 Tuas South Street 3, S(638026)  
Website: [www.streampeak.com.sg](http://www.streampeak.com.sg)

## Key Features

- Finer active ingredients to allow even and faster absorption
- Multi-laminated packing that is moisture- and oil-proof
- A superior outer film that allows oxygen to be absorbed without causing its active powder to have direct contact with food
- Retains flavours, color, aroma, and quality of food products



## Product Specifications

Technical Specifications	
<b>Choosing Size</b>	Size ranges from 10 cc to 3000 cc. Formula to measure the volume of oxygen in your container,  $\text{Oxygen in container (ml)} = (\text{Air volume in container (ml)} - \text{weight of product (g)/specific gravity}) \times 0.21$
<b>Can be packed with</b>	<ul style="list-style-type: none"><li>• Pet food</li><li>• Bakery products</li><li>• Dehydrated food and nuts</li><li>• Jerky and processed meat products</li><li>• Pharmaceutical products</li></ul>
<b>Forms Available</b>	<ul style="list-style-type: none"><li>• Sachet form</li><li>• Spool form</li></ul>

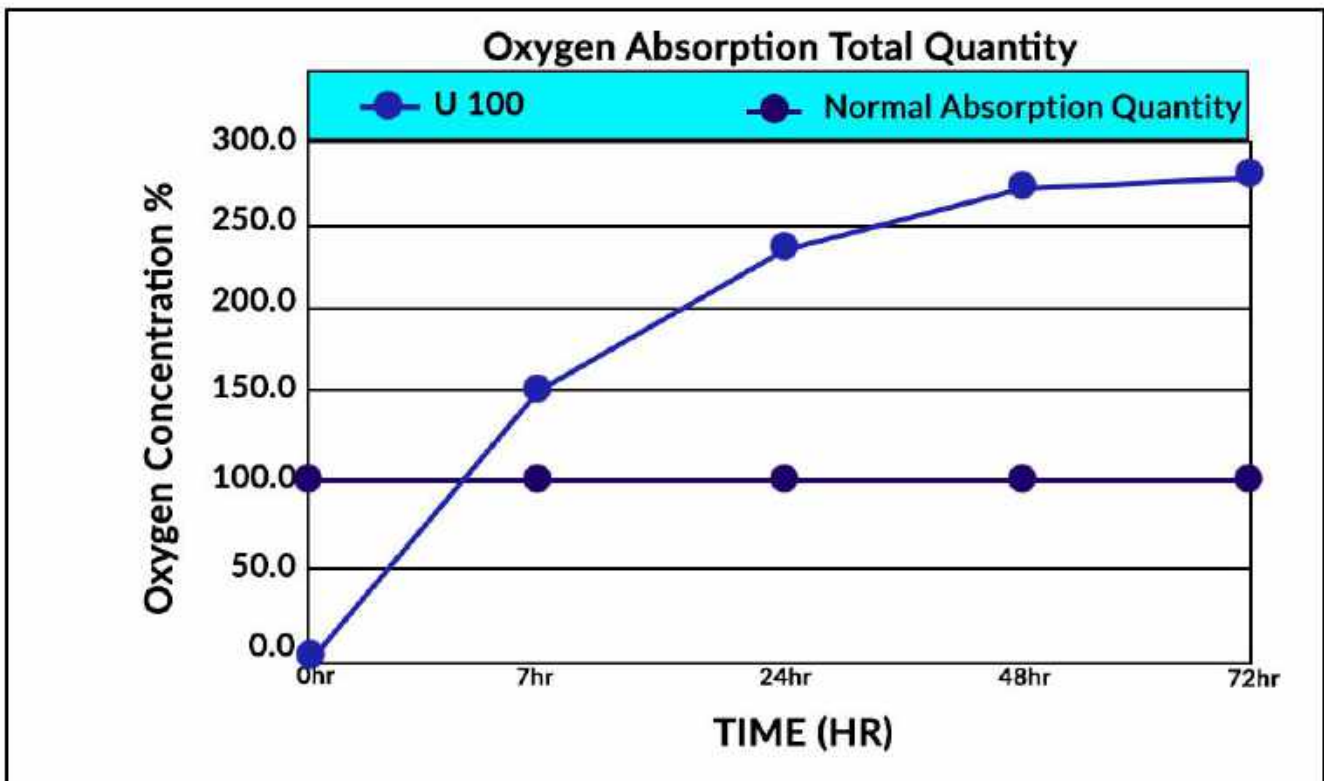
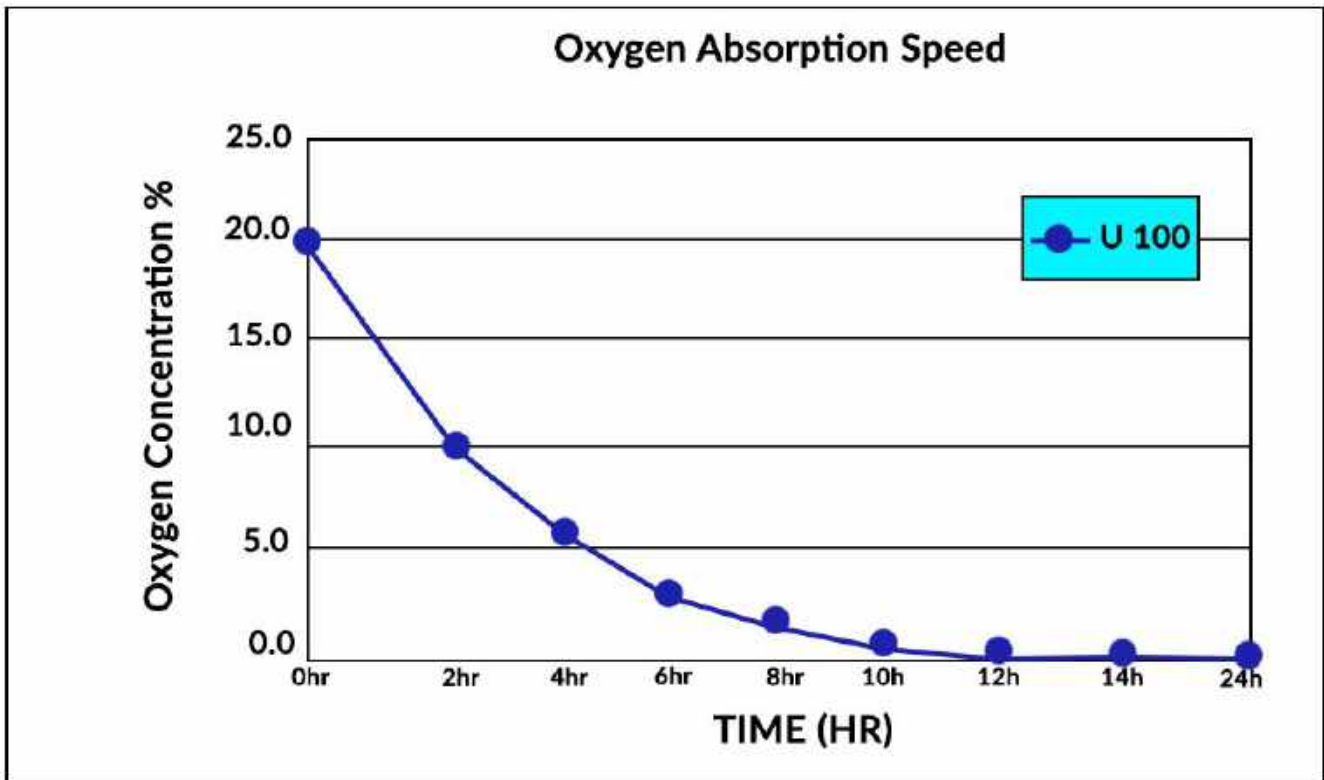

## How to use Oxygen Absorber

- 1) Oxygen absorber can be used only one time. Never re-use old oxygen absorber.
- 2) After opening the bag in which oxygen absorber was bagged, please use out the all in 4 hours.
- 3) Please check the out packing bag is strongly degassed and oxygen indicator is pink. In case the bag is puffy or indicator turns blue, please don't use it and send it to sale dealer and ask for replacement.

### single pouch



Outer bag clings to products



Outer bag is puffy and products fall down

### continous pouch

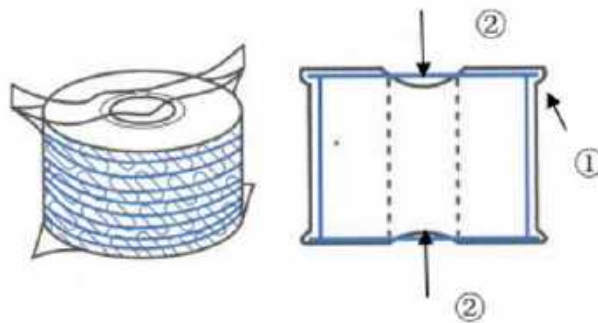

1. Outer bag clings to products
2. Deep sag

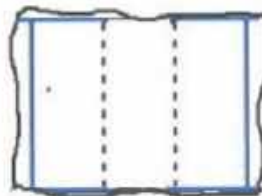

1. Outer bag is puffy
2. Shallow sag or flat

## Using O-Sorb

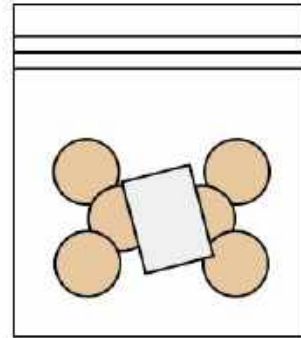
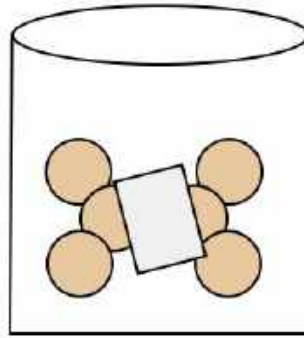
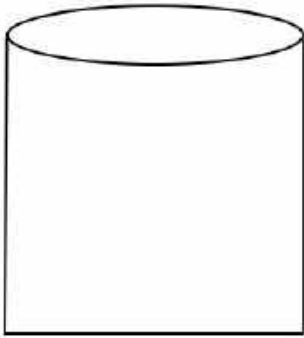

1) Use a high gas barrier bag

2) Use suitable size O-Sorb

3) Completely seal the bag

## O-Sorb the food fresh keeper

Amount to use depends on the oxygen volume of the void space (the space not occupied by the food/goods) in a package. Oxygen presents in 20% of air volume.

If the void space is 100 ml, it contains 20 ml of oxygen. Hence, a packet of U-20 will suffice.

Product Code	Nominal oxygen capacity (ml)	Nominal air capacity (ml)	Dimension of absorber (mm)	Number per Carton
U-20	20	100	30X38	10000 (500 X 20bags)
U-30	30	150	30X40	10000 (500 X 20bags)
U-50	50	250	40X40	6000 (300 X 20bags)
U-100	100	500	40X45	U-24000 (200 X 20bags)

## Comparison of Products with and without "Oxygen Absorber"

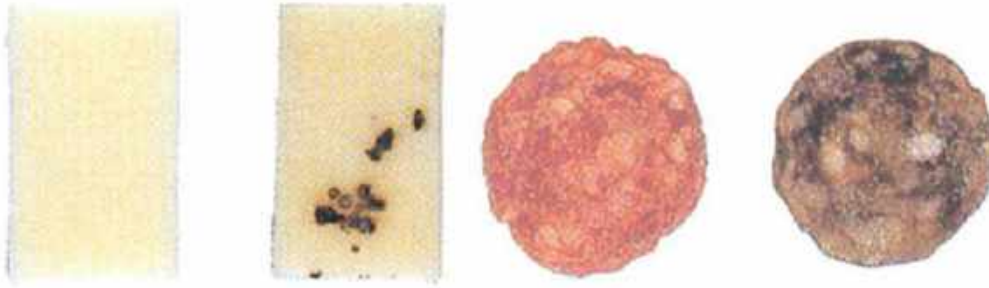

## Reaction Time in a 500cc sealed bag

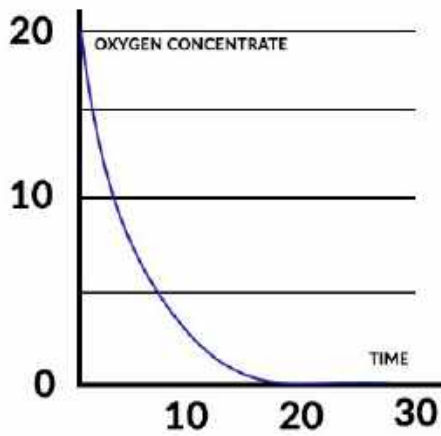

## Oxygen indicators



No Oxygen (0.1% or less)



Oxygen exists (0.3% or more)

With oxygen indicator, visual monitoring of sealed bags for barrier bleaches is possible. This is good for quality assurance.

**Physiological effects of oxygen absorber on consumer's perception on Product goodness**

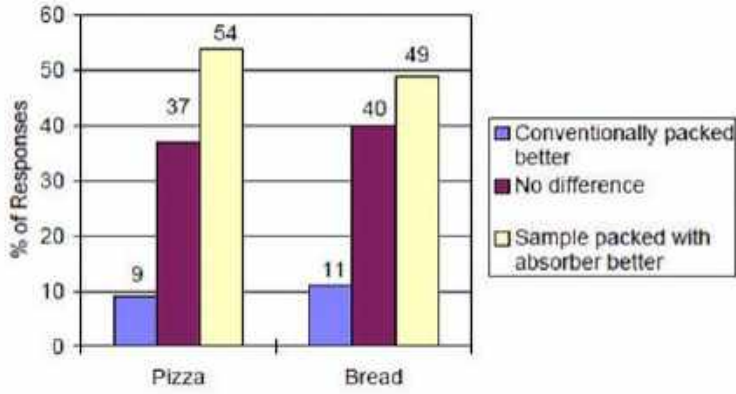

**What can O-sorb be used on?**



## What size O-sorb to get?

It depends on the volume of the empty space in your package. For example, if the volume of empty space is 100ml, because air is made out of 20% oxygen, there will be 20 ml of oxygen present in your package.

Some of the sizes available are U-20, U-30, U-50, U-100, with the number indicating the capacity of oxygen that is able to be absorbed. In the example above, as there is 20ml of oxygen present, a packet of U-20 will suffice nicely for your purposes.

Reference Number	Description	Quantity
FOF1A	UF100(Frozen type)	4000PCS/CTN
FOK03	K-30	10000PCS/CTN
FOK05	K-50	6000PCS/CTN
FOK1A	K-100	4000PCS/CTN
FOS01	U-10	15000PCS/CTN
FOS02	U-20	10000PCS/CTN
FOS03	U-30	10000PCS/CTN
FOS03R	U-30	10000PCS/CTN
FOS05	U-50	6000PCS/CTN
FOS1A	U-100	4000PCS/CTN
FOS1B	U-1000	600PCS/CTN
FOS2B	U-2000	280PCS/CTN
FOS3B	U-3000	225PCS/CTN
FOS3R	U-30R1500	3000PCS/CTN

## Related Products



Ethylene Absorber Sachets



Biolog USB



Silica Gel



Humidity Indicator Card



**STREAM PEAK INTERNATIONAL PTE LTD**

Tel: +65 6610 7921 | Fax: +65 6862 2520

Email: [enquiry@streampeak.com.sg](mailto:enquiry@streampeak.com.sg)

*Valuing Relationships, Protecting Goods*

Address: 26 Tuas South Street 3, S(638026)

Website: [www.streampeak.com.sg](http://www.streampeak.com.sg)