

THIS DESIGN IS THE PROPERTY OF BROWNELL LTD
AND MAY NOT BE COPIED OR REPRODUCED
WITHOUT THEIR PRIOR WRITTEN PERMISSION

DRG No
BL/D 8438/01-04 INST
USED ON

THIRD ANGLE PROJECTION

REMOVE ALL SHARP EDGES UNLESS SPECIFIED

DO NOT SCALE - ASK

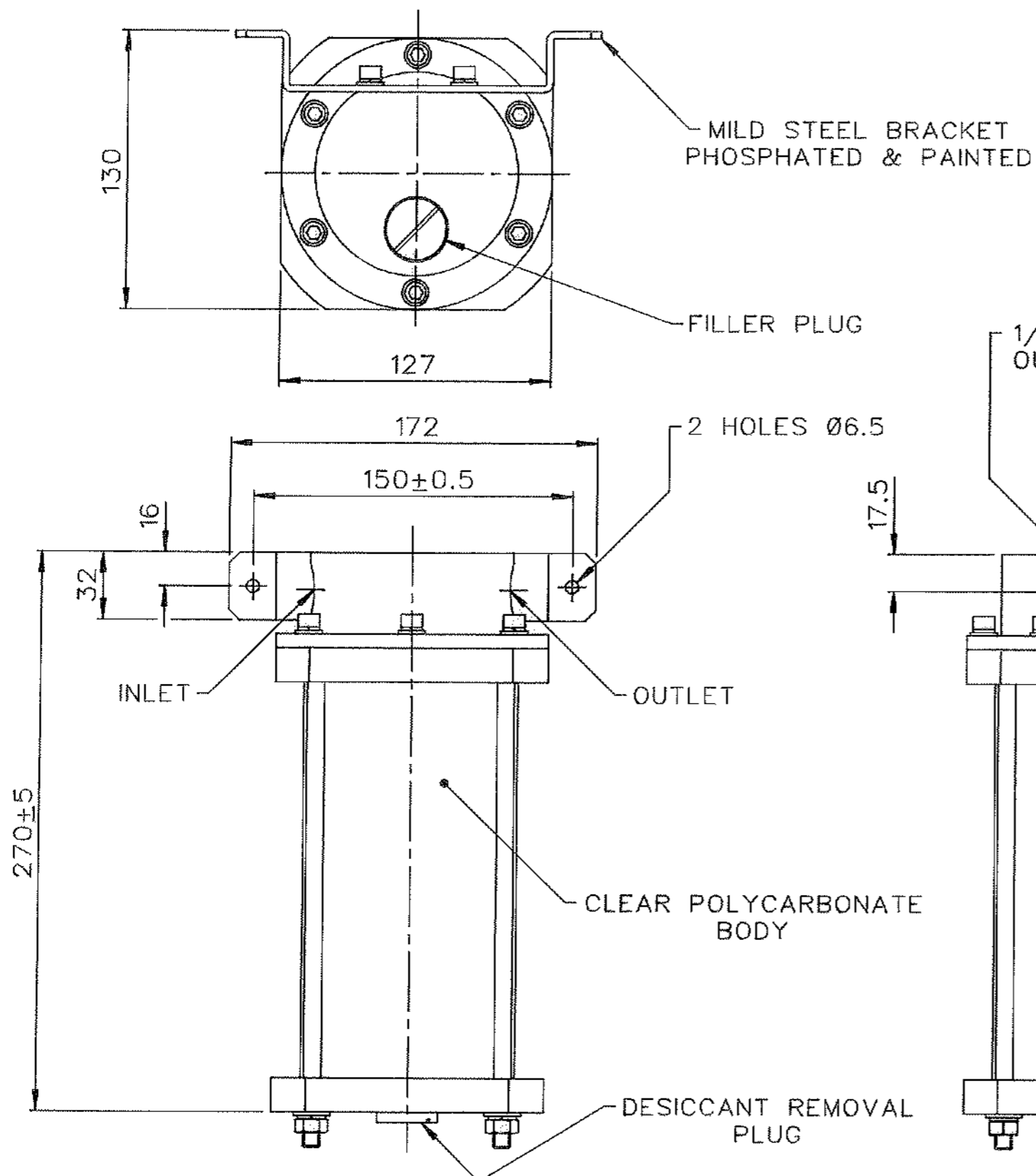
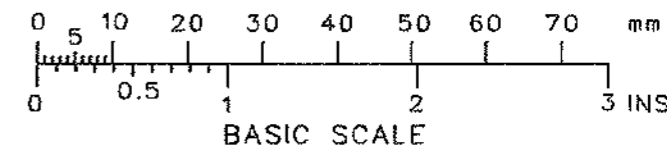

DRG No	DESICCANT	NOMINAL FLOW RATE
BL/D8438/01	4A MOLECULAR SIEVES	25 L/MIN AT N.T.P.
BL/D8438/02	13X MOLECULAR SIEVES	25 L/MIN AT N.T.P.
BL/D8438/03	BEADED SILICA GEL	25 L/MIN AT N.T.P.
BL/D8438/04	4A MOLECULAR SIEVES	100 L/MIN AT N.T.P. WITH A MAXIMUM PRESSURE DIFFERENTIAL OF 4 PSIG

NOTES

- DESICCANT CHARGES INCLUDE A 20% MIX (BY WEIGHT) OF INDICATING BEADED SILICA GEL.
- INLET & OUTLET PORTS ON BL/D8438/04 ARE FITTED WITH COMPRESSION FITTINGS.

SPECIFICATION

NOMINAL DESICCANT CONTENT: 1 Kg.
OPERATING PRESSURE: 100 PSI MAX.
PROOF PRESSURE: 200 PSI MAX.
NOMINAL OUTLET FILTRATION: 25 MICRON.

/04 - DES WAS BSG	5735	D	6/12/00
/04 ADDED	5646	C	4/5/00
20% DES MIX WAS 10%	5534	B	18/10/99
		A	23/8/99
CHANGE	MOD No	ISSUE	DATE

MATERIAL ALUM ALLOY	PROTECTIVE TREATMENT ANODISED	TOLERANCES UNLESS STATED ±3	BROWNELL LIMITED LONDON NW10	CUSTOMER REF.	DRAWN LJ	CHECKED A
EST. WT. —		DIMNS IN INS /mm SCALE (ORIGINAL) N.T.S	TITLE PIPELINE DRYER	DRAWING No BL/D 8438/01-04 INST		